

MANUFACTURING CORP.

**SPECIFICATIONS, INSTALLATION INSTRUCTIONS AND
TROUBLE-SHOOTING GUIDE FOR UL LISTED STACK PACK
SERIES 29 AND NON-UL LISTED STACK PACK SERIES 30
MOTORIZED STACK DAMPERS SERIES 29 AND 30
THIS STACK DAMPER IS FOR USE ON OIL FIRED SYSTEMS ONLY
(Request Form For Gas Fired Appliances)**

WARNING

- **ALL WIRING MUST BE IN ACCORDANCE WITH NATIONAL ELECTRICAL CODES, CLASS 1 (REMOTE CONTROL AND SIGNALLING CIRCUITS), AND MUST ALSO COMPLY WITH APPLICABLE LOCAL ELECTRICAL ORDINANCES, CODES AND REGULATIONS. "HOT LEG" MUST HAVE A COMMON DISCONNECT AND MUST BE CONNECTED WITH CORRECT POLARITY. FAILURE TO OBSERVE THIS CAUTION MAY LEAD TO ELECTRICAL SHOCK AND/OR EQUIPMENT DAMAGE OR MALFUNCTION.**
- **CLEARANCES OF NOT LESS THAN 18 INCHES (457.2 MM) MUST BE MAINTAINED FROM COMBUSTIBLE MATERIALS, WITH PROVISIONS FOR ACCESS.**
- **THIS DEVICE MUST BE INSTALLED IN A VENTING SYSTEM OR SECTION OF A VENTING SYSTEM SO THAT IT SERVES ONLY THE SINGLE APPLIANCE FOR WHICH IT IS INSTALLED.**
- **INSTALLATION OF THIS DEVICE SHOULD BE PERFORMED BY A QUALIFIED INSTALLING AGENCY IN COMPLIANCE WITH ALL LOCAL, STATE AND FEDERAL CODES.**
- **DO NOT REDUCE VENT PIPE SIZE TO ACCOMMODATE THE STACK DAMPER. STACK DAMPER SIZE MUST BE AT LEAST THE SAME SIZE AS OR LARGER THAN ORIGINAL VENT PIPE.**
- **DEVIATION FROM THESE INSTRUCTIONS IN INSTALLATION OR USE MAY LEAD TO A DANGEROUS CONDITION.**

SHOULD INSTALLATION PROBLEMS ARISE, CONSULT THE TROUBLE-SHOOTING GUIDE ON REAR COVER. IF PROBLEMS PERSIST, CALL OUR TOLL-FREE TROUBLE-SHOOTING NUMBER [REDACTED] OUTSIDE OF NEW YORK. IN NEW YORK STATE, DIAL DIRECT [REDACTED]



I. INTRODUCTION

This product is an automatic, motorized stack damper that has been developed to increase the efficiency of heating systems by reducing standby losses from the heating apparatus and the conditioned air space surrounding it. The damper closes the chimney vent when the burner is off, and fully opens it again when combustion is required. The concept is similar to the opening and closing of a fireplace flue, except that the operation is completely automatic. A safety interlock has been added which prevents burner operation unless the damper is in an open position. A closed damper substantially reduces standby losses on boilers, furnaces and water heaters. Motorized stack dampers are not to be installed on sealed combustion systems or on oil fired appliances having a constant burning pilot. Motorized dampers do not "Reclaim Wasted Heat". Motorized dampers prevent heat from being wasted by the natural draft of the chimney when the burner is off.

II. DESCRIPTION

The damper should be mounted on the vent pipe directly after, on the chimney side of, the barometric damper.* When the damper is in the closed position, it will prevent residual heat in the heating appliance from being drawn up the chimney vent by its natural draft. A closed damper will also prevent conditioned air from being pulled through the barometric damper and up the chimney by the same stack effect. When combustion is required, the damper will rotate to its open position BEFORE an integral end switch activates the burner circuit. If the damper does not rotate to its open position, the burner circuit will not be activated. If installed properly, the electrical circuits in this product are designed not to override existing limit controls. When the combustion requirement has been satisfied, the burner will go off immediately, and after a three minute time delay, the damper will slowly rotate to its fully closed position. This delay has been designed to provide a post-purge which reduces nozzle "coking" and eliminates annoying combustion odors. The damper is spring loaded and will return to an open position on power failure. This feature enables the normal stack draft to effectively vent any unburned fumes that may accumulate during the power outage. Cast iron vent section construction allows for close tolerance manufacture and a tight fitting damper blade which gives maximum system efficiency.

This automatic damper consists of two separate components. 1. The Damper Section, which is constructed of durable cast iron. This unit fits into the system venting and contains the low voltage motor used to drive the integral damper to a closed position. 2. The Relay Unit, which mounts on a standard 4x4 electrical box and is the "trigger" used to activate the damper operation. A three minute solid state delay timer is incorporated in the circuitry to provide a post purge period.

Potential fuel savings can range to 20% or more, depending on the following factors:

1. geographical location of dwelling;
2. the size of heating plant relative to heat loss of dwelling;
3. location of heating plant within dwelling;
4. diameter of venting system;
5. total height of chimney above heating plant;
6. outdoor temperatures and sustained wind velocities over a given period of time;
7. settings of operating and limit controls on heating plant;
8. type of heating plant used (furnace, boiler, or water heater);
9. source of domestic hot water, temperature of water, and amount used;
10. room thermostat settings;
11. infiltration factors of dwelling;
12. number of heating zones;
13. day/night thermostats being used and the hours and degrees of setback;
14. chimney vent friction;
15. type of stack damper used.

Motorized dampers for oil fired equipment are available through all normal heating distribution channels. Although we have attempted to make field installation simple and safe, a faulty mechanical installation or improper electrical wiring can make the damper inoperative or potentially dangerous. **IT IS FOR THIS REASON THAT WE STRONGLY RECOMMEND INSTALLATION BY TRAINED, QUALIFIED HEATING CONTRACTORS OR OIL BURNER SERVICEMEN.** When properly installed, the unit is maintenance-free. It is designed to provide many years of dependable service, giving both comfort and economy.

NOTE: UL Listed units (Series 29) are built to the exacting specifications to which UL tested before listing. Non-UL Series 30 may utilize some assembly components which are not UL listed and therefore Series 30 dampers have not been submitted for UL testing. Both Series 29 and Series 30 dampers are high quality products which have been built with the utmost care and concern for the installer and consumer.

* This is the recommended location for maximum efficiency. If installation difficulties arise, the damper may be installed between the appliance and the barometric damper, resulting in a loss of efficiency.

III. GENERAL INFORMATION

Vent Size	Vent Section Material	Damper Vane Material	Free Area (\pm) 0.5 in ²	% By Pass* Closed	Shipping Weight
4"	cast iron	16ga.Al/Stl.	13 in ²	4.0%	5 lbs.
5"	cast iron	16ga.Al/Stl.	20 in ²	2.5%	6 lbs.
6"	cast iron	16ga.Al/Stl.	24 in ²	2.0%	7 lbs.
7"	cast iron	16ga.Al/Stl.	33 in ²	1.5%	8 lbs.
8"	cast iron	16ga.Al/Stl.	44 in ²	1.2%	10 lbs.
9"	cast iron	16ga.Al/Stl.	56 in ²	1.0%	12 lbs.
10"	cast iron	16ga.Al/Stl.	78 in ²	0.6%	14 lbs.
12"	cast iron	22ga.St/Stl.	104 in ²	0.3%	18 lbs.

*with one knock-out removed, multiply by a factor of 2.

SERIES 29 . . . UL LISTED.

SERIES 30 . . . NON-UL LISTED.

IV. ELECTRICAL

Provide common 110/120 VAC power supply to time delay relay and heating plant, and provide common disconnect means with overload protection as required.

Thermostat Anticipator Setting

Set for normal system requirement. Settings do not change with addition of vent damper.

Damper Relay

contact rating 10 amps at 120 VAC
transformer (internal) 120/24 VAC 20 VA
time delay 3 Minutes - solid state
test switch normally open, spring loaded, slide type
mount 4" x 4" electrical utility box

Minimum Wiring Requirement

18 gauge, 90°C. Copper wire

Damper Drive Motor

power draw 6 watts at 24 VAC when closed or closing
torque 40 in/oz minimum
timing close 15 seconds, open 5 seconds (nominal)
characteristic power close, normally open
type synchronous
switching wafer type/coin silver contacts, two position, 90° movement

V. MECHANICAL

drive rod 1/8" x 1/4" x required length, chrome plated cold rolled steel
mounting plate aluminum, 14 gauge
operator cover cold rolled steel, painted
maximum allowable stack temperature 930°F. above ambient

VI. FEATURES

Damper opens on power failure • No required change in wiring of existing limit controls • Life-cycle test in excess of 100,000 operations at 1000°F. • Cast iron construction of vent pipe section • 90% open before burner "ON" signal • Three-minute closing delay after burner "OFF" • Burner "OFF" before start of damper close • Normal limit control of burner operation with damper disabled open • No burner operation with damper disabled closed • External damper position indicator • Operational test switch • Direct drive, no linkage end switch for proving damper open • Series 29 damper system UL Listed • Cast iron vent section allows for close tolerance manufacture, distortion-free installation, and minimum bypass with a tight closing damper vane • 5 second open does not cause lockout with timed safety controls • Compatible with all stack relays and cad cell primary controls.

VII. DIMENSIONS

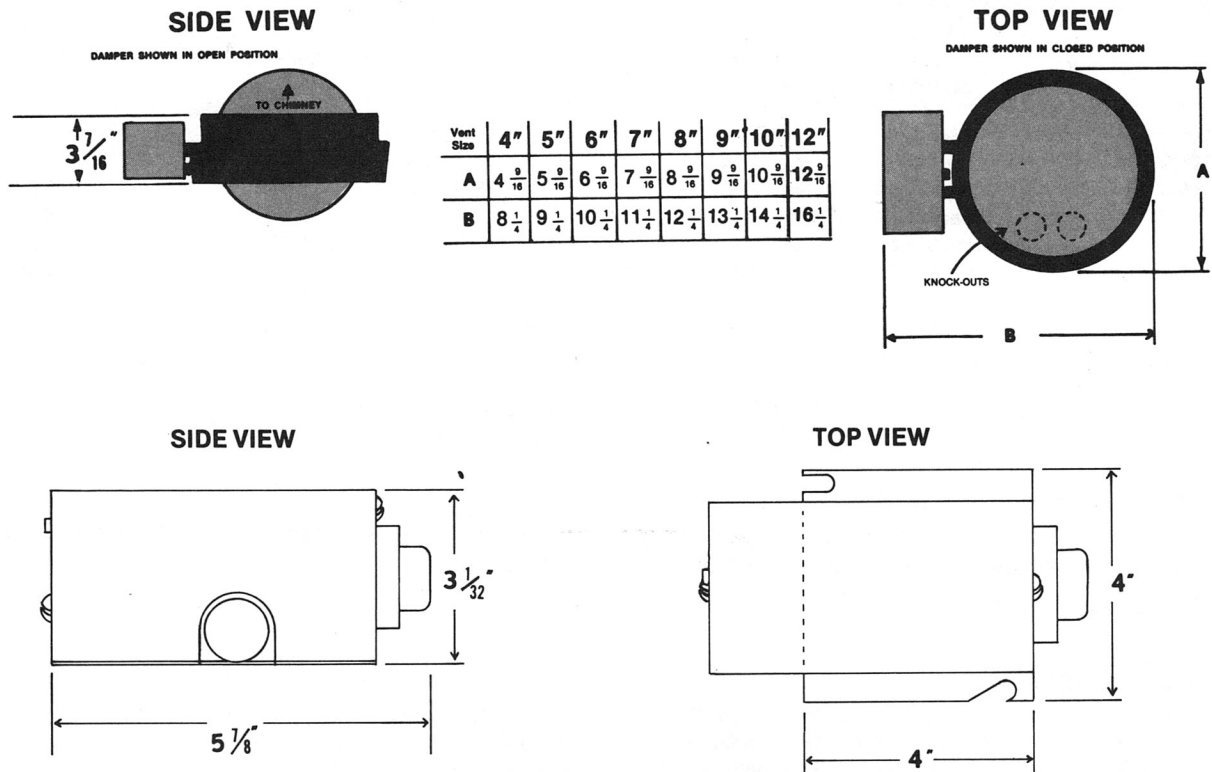

VIII. INSTALLATION

A. BEFORE YOU START TO INSTALL:

1. Read cautions as listed on cover page and on the brown envelope.
2. System should be visibly checked for defects such as rusting vent pipe, poor burner adjustment, and oil leaks. Problems should be corrected before proceeding.
3. Turn off electrical power and wait for the system to cool.
4. Select a safe, convenient location* allowing a minimum of 18 inches (457.2mm) of clearance between the stack damper and walls, ceilings, floor, or combustible material. (See Fig. 2, 3, and 4).
5. Carefully unpack the unit. The damper is spring loaded and should drive to an open position when it is removed from the packing. **DO NOT FORCE IT CLOSED!** Forcing the damper may damage the gear train and void the warranty.

B. NOW, PROCEED AS FOLLOWS:

1. Separate the vent pipe at the selected installation point and insert the casting. The arrow imprint on the open damper should point in the direction of vent gas flow (towards chimney).
2. Re-assemble the vent piping. Be sure the casting is well seated. See Fig. 5 if support or screw-together assembly is required.
3. Mount the time delay relay on a 4x4 electrical box at a convenient point on the appliance jacket or on adjacent wall or beam where the ambient temperature will not exceed 100 °F.
4. Wire the system as shown in the diagrams and in accord with local codes (see diagrams).
5. Restore electrical power.

C. AFTER INSTALLATION:

1. Operate system through three (3) complete cycles to check for proper opening and closing sequence (see damper position indicator, Fig. 6), and proper high limit control of burner operation. **REMEMBER, THERE IS A NORMAL THREE MINUTE DAMPER CLOSING DELAY AFTER THE BURNER GOES OFF.** For test purposes, the three minute delay can be temporarily eliminated by holding the "PUSH TO TEST" switch on the time delay relay.
2. If the damper does not come to the fully open or fully closed positions, check for interference by the vent pipe. (See Fig. 9).
3. Check the "trouble-shooting guide" if problems arise with the installation.

*Installation BETWEEN barometric damper and heating appliance is allowable but will reduce fuel saving efficiency.

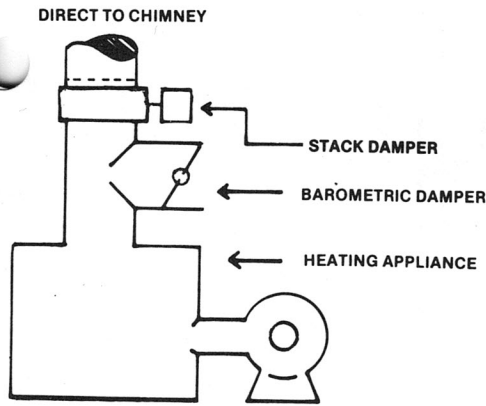

VERTICAL INSTALLATION
Fig. 1

Use Band Iron For Support If Required
(Replace any damaged or rusted vent pipe)

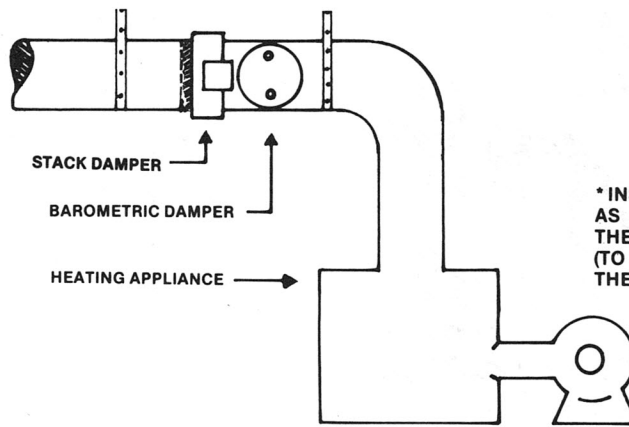

HORIZONTAL OR SLOPING INSTALLATION*
Fig. 2

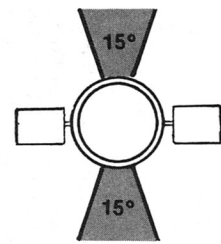

*INSTALL OPERATOR IN ANY POSITION AS SHOWN ABOVE. DO NOT INSTALL THE OPERATOR ABOVE THE VENT PIPE (TO AVOID EXCESSIVE HEAT) OR BELOW THE VENT PIPE (TO AVOID POSSIBLE CONDENSATE DAMAGE).

Fig. 3

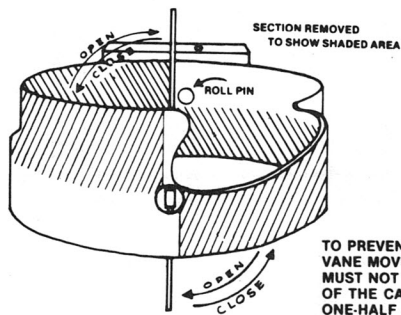

CAUTION
TO PREVENT INTERFERENCE WITH DAMPER VANE MOVEMENT, SCREWS OR POP RIVETS MUST NOT BE LOCATED IN SHADED AREAS OF THE CASTING, AND MUST NOT EXCEED ONE-HALF (1/2) INCH IN LENGTH.

Fig. 4

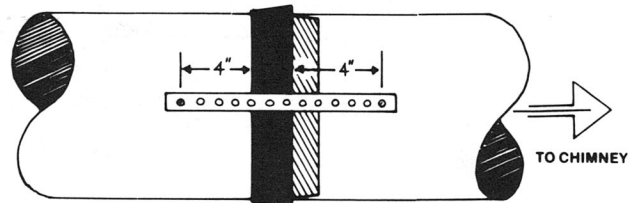

INSTALL BAND IRON AS REQUIRED. USE 1/4" SELF-TAPPING SCREWS OR POP RIVETS AND LOCATE THEM A MINIMUM OF 4" FROM THE EDGE OF THE CASTING.

Fig. 5

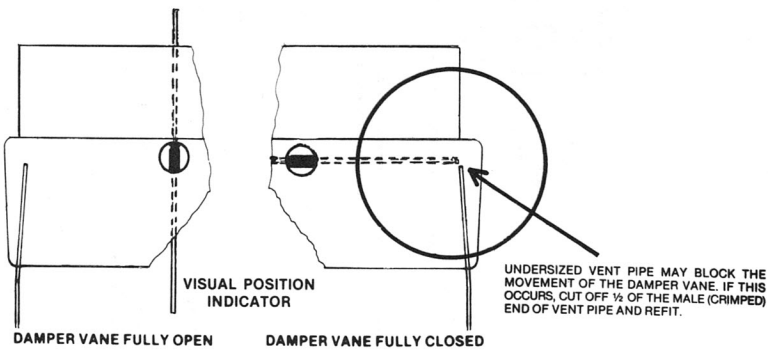

DAMPER POSITION INDICATOR MAY BE VIEWED THROUGH HOLE IN THE CASTING ON THE SIDE OPPOSITE THE OPERATOR.

Fig. 6

CAUTION
DO NOT USE ONE STACK DAMPER TO CONTROL 2 HEATING APPLIANCES

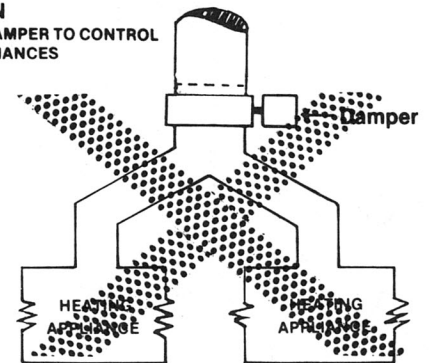

DANGEROUS WRONG WAY

Fig. 7

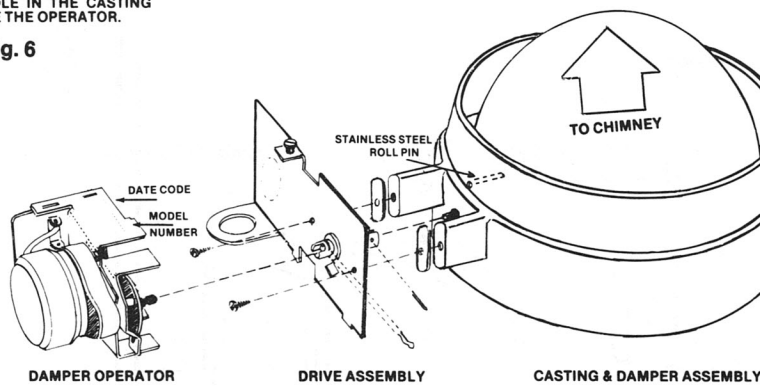

Fig. 8

NOTE: Consult your local distributor for part numbers and pricing.
FOR SAFETY REASONS, only component assemblies as shown are available.

ROOM THERMOSTAT
24V or 110V

NOTE: This is a pictorial layout showing approximate wiring and location of Stack Pack components when integrated into an oil fired system.
Use wiring diagrams on Page 7 when wiring the Stack Pack.

LEGEND
 Line Voltage _____
 Low Voltage _____
 Line or Low Voltage - - - - -

**SEQUENCE OF EVENTS
STACK PACK - OIL FIRED**

Room thermostat or Temperature Limit Control calls for heat. Power is switched through Primary Control to Stack Damper Relay unit.
 Stack Damper Relay unit allows damper operator to open.
 When damper reaches the open position, the damper interlock switch (end switch) signals the Stack Damper Relay unit to run the burner.
 When heating demand has been satisfied, the room thermostat or the temperature limit control interrupts the power to the Stack Damper Relay unit, shutting down the oil burner immediately.
 After a three-minute delay period, the Stack Damper Relay unit signals the Stack Damper Operator to close the damper until the next call for heat.

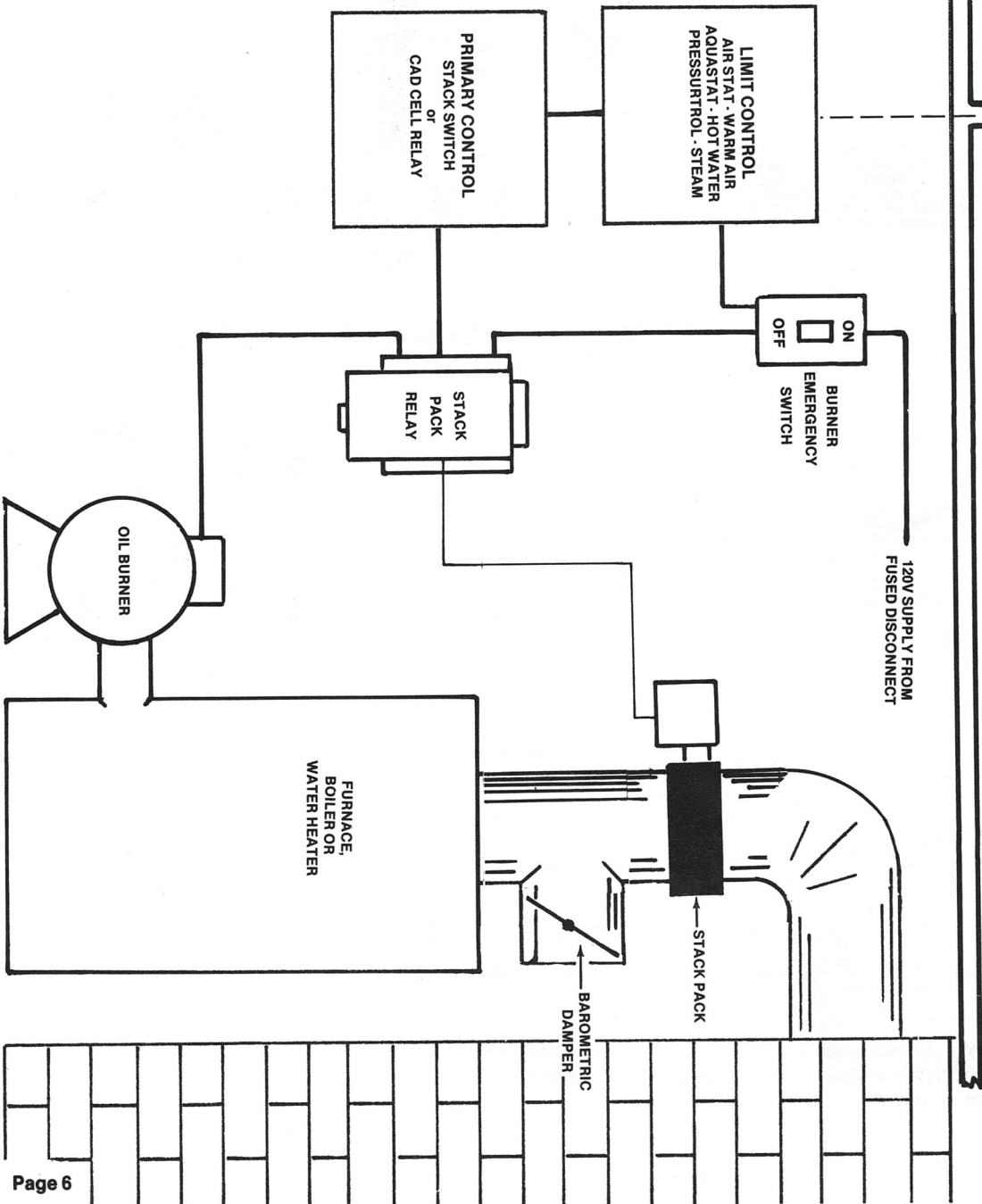

L2
WHITE

L1
BLACK



EXTERNAL HIGH LIMIT (IF USED) SEE



PRIMARY CONTROL MAY HAVE NUMBERED TERMINALS OR COLOR CODED WIRE LEADS AS INDICATED.

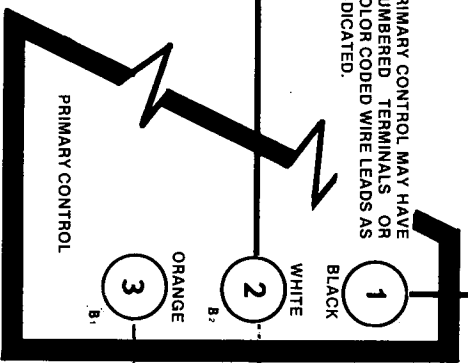

WIRING LEGEND
 EXISTING LINE VOLTAGE —————
 FIELD - WIRED LINE VOLTAGE - · - · - · -
 FIELD - WIRED LOW VOLTAGE - - - - -

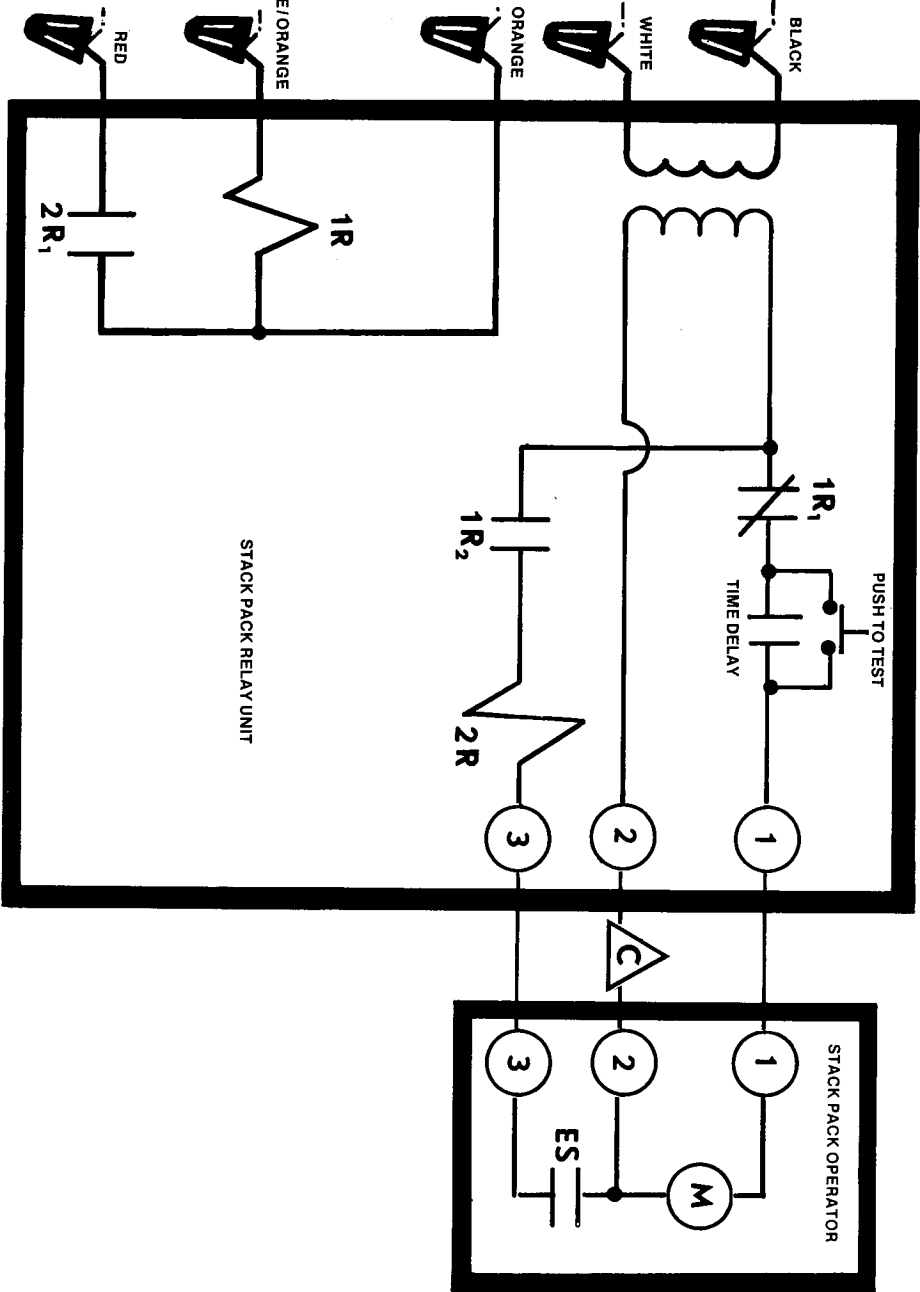

WIRING PROCEDURE

1. TURN OFF ELECTRIC SUPPLY.
2. Connect Black and White leads of Damper Relay to 110VAC power supply.
3. Wire White/Orange tracer lead of Damper Relay to grounded (neutral) leg of burner motor and ignition transformer.
4. Disconnect existing wire (hot lead of burner motor and ignition transformer) from terminal 3 of the Primary control and connect it to the Red lead of the Damper Relay.
5. Wire the Orange lead of the Damper Relay to terminal 3 of the Primary Control.



POWER SUPPLY, DISCONNECT MEANS AND OVERLOAD PROTECTION PROVIDED AS REQUIRED.



CONSTANT IGNITION SHOWN.



USE 90°C RATED COPPER WIRE FOR LOW VOLTAGE CONNECTIONS BETWEEN DAMPER RELAY AND OPERATOR; WIRE N.E.C. CLASS 1 REMOTE CONTROL AND SIGNALLING CIRCUITS.



MUST BE WIRED TO GROUNDED (NEUTRAL) LEG OF BURNER MOTOR AND IGNITION TRANSFORMER. IF BURNER MOTOR NEUTRAL LEG IS SAME POLARITY AS WHITE L2 LEG - ALL WHITE LEADS MAY BE TIED TOGETHER.



EXTERNAL HIGH LIMIT SHOWN - IF HIGH LIMIT IS PART OF PRIMARY CONTROL, ATTACH BLACK LEAD FROM STACK PACK RELAY TO #1 TERMINAL OR BLACK LEAD OF PRIMARY CONTROL.

TROUBLE-SHOOTING GUIDE

(Listed in order of probability)

<u>SYMPTOM</u>	<u>POSSIBLE CAUSE</u>	<u>REMEDY</u>
Heating required and burner will not operate. Damper closed.	Thermostat is set wrong.	Reset thermostat (heat or hot water) to call for heat.
Heating required and burner will not operate. Damper open.	No electrical power.	Turn on switch - replace fuse - reset circuit breaker.
	Improper wiring.	Recheck and correct any wiring errors in line and low voltage circuits.
	Stack switch or cad cell malfunction.	Check reset button: repair or replace control.
	Defective burner components.	Check, repair or replace burner components.
	Damaged or defective damper operator.	Replace damper operator.
	Damaged or defective time delay relay.	Replace time delay relay.
Burner operates normally, damper will not close.	Time delay in normal operation.	Wait at least 3 minutes for damper to close, before checking further.
	Damper is blocked open.	Check for free damper movement, and remove blockage.
	Improper wiring.	Recheck and correct any wiring errors in line and low voltage circuits.
	Damaged or defective time delay relay.	Replace time delay relay.
Time delay relay chatters.	Incompatible solid state oil burner primary control. Robertshaw SJ4000 series.	The Robertshaw line of solid state primary controls (SJ4000 series) are not compatible. Consult factory for wiring modification.
	Defective time delay.	Replace time delay relay.
Burner will not operate. Damper closed and will not open.	No call for heating.	Reset thermostat (heat or hot water) to call for heating.
	Damper is blocked closed.	Check for free damper movement and remove blockage.
	Improper wiring.	Recheck and correct any wiring errors in line and low voltage circuits.
	Broken return spring.	Inspect under mounting plate for broken return spring. Replace with complete drive assembly.
Burner will not operate. Damper operates normally.	Improper wiring.	Recheck and correct any wiring errors in line and low voltage circuits.
	Stack switch or cad cell malfunction.	Check reset button: repair or replace control.
	Defective burner components.	Check, repair or replace burner components.
Burner operates normally. Damper operates normally. Bad odor is detectable.	Insufficient draft over fire.	Clean clogged flue passages and readjust barometric damper.
	Normal time delay insufficient for system.	Open vent pipe and remove two knock-outs from damper vane. Be careful not to damage or distort vane.
Burner operates before damper is open.	Improper wiring.	Recheck and correct any wiring errors in line and low voltage circuits.
Damper vane stops in other than fully open or fully closed position.	Damper is blocked.	Check for maximum 90° damper movement. If less than 90°, remove blockage.
	Missing roll pin damper stop.	Replace stainless steel roll pin.
	Broken coupling.	Inspect and replace with complete drive assembly.
	Broken return spring.	Inspect under mounting plate for broken return spring. Replace with complete drive assembly.
	Broken spring stop.	Inspect and replace complete drive assembly.
Intermittent burner operation. Damper operates normally.	Bent or broken coupling.	Replace complete drive assembly.
	Loose or broken wires.	Recheck and correct any wiring errors in line voltage circuit.
	Damaged or defective switch.	Replace damper operator.