

FLAIR INTERNATIONAL CORPORATION  
600 OLD WILLETS PATH  
HAUPPAUGE, NEW YORK 11788 U.S.A.  
TEL.: (516) 234-3600 FAX: (516) 234-3610

**SPECIFICATIONS, INSTALLATION INSTRUCTIONS AND  
TROUBLE-SHOOTING GUIDE FOR STACK PACK  
MOTORIZED VENT DAMPER SERIES SK22  
FOR USE ON GAS-FIRED SYSTEMS ONLY.**

**Information for oil-fired appliances available on request.**

**A.G.A. DESIGN CERTIFIED IN COMPLIANCE WITH ANSI Z21.66**

**WARNING**

- THIS DEVICE IS FOR INSTALLATION ON A GAS-FIRED APPLIANCE LISTED BY A NATIONALLY RECOGNIZED TESTING AGENCY.
- THIS DEVICE MUST BE INSTALLED BY A QUALIFIED INSTALLING AGENCY, IN COMPLIANCE WITH LOCAL CODES OR, IN THE ABSENCE OF LOCAL CODES, WITH THE NATIONAL FUEL GAS CODE, ANSI Z223.1-(MOST CURRENT EDITION) AND IF APPLICABLE THE NATIONAL ELECTRICAL CODE, ANSI/NFPA NO. 70-(MOST CURRENT EDITION).
- THE QUALIFIED INSTALLER MUST NOT NEGATE THE ACTION OF ANY EXISTING SAFETY OR OPERATIONAL CONTROL.
- THIS DEVICE IS CONSTRUCTED TO CONFORM TO ANSI Z21.66 - (MOST CURRENT EDITION) FOR RETROFIT; SERIES SK22 MUST BE INSTALLED WITHOUT THE USE OF ADDITIONAL OR REDUNDANT GAS VALVES. THIS SERIES DAMPER HAS A 10% BYPASS AND A TEMPERATURE LIMIT AS REQUIRED UNDER PARA 1.5.8 OF ANSI Z21.66 - (MOST CURRENT EDITION).
- THIS DEVICE MUST BE INSTALLED AFTER THE APPLIANCE DRAFT HOOD, AS CLOSE TO THE DRAFT HOOD AS PRACTICABLE, AND WITHOUT MODIFICATION OF THE DRAFT HOOD.
- THIS DEVICE MUST BE INSTALLED ONLY ON AN APPLIANCE CONNECTED TO A FACTORY BUILT CHIMNEY OR VENT COMPLYING WITH A RECOGNIZED STANDARD, OR A MASONRY OR CONCRETE CHIMNEY LINED WITH A LINING MATERIAL ACCEPTABLE TO THE AUTHORITY HAVING JURISDICTION.
- THIS DEVICE MUST BE LOCATED IN A VENTING SYSTEM OR SECTION OF A VENTING SYSTEM SO THAT IT SERVES ONLY THE SINGLE APPLIANCE FOR WHICH IT IS INSTALLED.
- THIS DEVICE SHALL NOT BE INSTALLED ON AN APPLIANCE WITH AN AUTOMATIC VALVE HAVING A MANUAL OPENER UNLESS THE MANUAL OPENER HAS BEEN RENDERED INOPERATIVE OR THE AUTOMATIC VALVE HAS BEEN REPLACED WITH AN AUTOMATIC VALVE NOT EQUIPPED WITH A MANUAL OPENER.
- CLEARANCE OF NOT LESS THAN 6 INCHES (152MM) MUST BE MAINTAINED FROM COMBUSTIBLE MATERIALS, WITH PROVISION FOR ACCESS.
- THE INSTALLER MUST FILL IN THE LABEL ON THE SIDE OF THE OPERATOR COVER.
- FOR INSTALLATION ON BOILER WITH TANKLESS COIL OR LOW LIMIT CONTROL, CONSULT FACTORY FOR SPECIAL WIRING DIAGRAMS.

SHOULD INSTALLATION PROBLEMS ARISE, CONSULT THE TROUBLE-SHOOTING GUIDE ON REAR COVER.  
IF PROBLEMS PERSIST, CALL OUR TECHNICAL SUPPORT LINE AT (516) 234-3600.



**I. INTRODUCTION**

This product is an automatic, motorized stack damper that has been developed to increase the efficiency of heating systems by reducing standby losses from the heating apparatus and the conditioned air space. The damper closes the chimney vent when the burner is off and fully open it when combustion is required. The concept is similar to the opening and closing of a fireplace flue, except that the operation is completely automatic. An interlock has been added, which prevents burner operation unless the damper is in an open position. A closed damper substantially reduces standby losses on boilers and furnaces.

**II. DESCRIPTION**

The damper must be installed after the appliance draft diverter and as close to it as practical, without modification. When the damper is in the closed position, it will prevent residual heat in the heating appliance from being drawn up the chimney vent by its natural draft. A closed damper will also prevent conditioned air from being pulled through the draft diverter and up the chimney by the same stack effect, if it is located within a heated area.

When combustion is required, the damper will rotate to its open position BEFORE an integral end switch activates the burner circuit. A special damper safety circuit checks the operation of the interlock switch on every cycle. If the interlock switch malfunctions closed, the safety circuit disables the damper to the open position while maintaining normal burner operation. The electrical circuits in this product are designed not to override the existing limit controls on the appliance when the product is properly installed.

The damper is spring loaded and will return to an open position on power failure. This feature enables the normal stack draft to effectively vent any unburned gas that may accumulate during the power outage. Cast iron vent section construction allows for close tolerance manufacture. (The unit has a 10% bypass and may be installed without gas valve redundancy.)

When the heating requirement has been satisfied, the burner will go off immediately, and the damper will remain open until the vent temperature drops below 225° F. The damper will then rotate to its fully closed position.

The damper has a built-in mechanical free-wheel lost motion feature that delays rotation of the vane for a few seconds, while protecting the gear train.

Potential fuel savings can vary from 10% to greater than 20% based on the following factors:

1. geographical location of dwelling;
2. the size of heating plant relative to heat loss of dwelling;
3. location of heating plant within dwelling;
4. diameter of venting system;
5. total height of chimney above heating plant;
6. outdoor temperature and sustained wind velocities over a given period of time;
7. settings of operating and limit controls on heating plant;
8. type of heating plant used (furnace, boiler or hot water heater);
9. source of domestic hot water, temperature of domestic water, and amount used;
10. room thermostat settings;
11. infiltration factors of dwelling;
12. number of heating zones;
13. day/night thermostat being used, and the hours and degrees of setback;
14. chimney vent friction;
15. type and model of stack damper used.

These conclusions have been reached by independent researchers and have not been verified by the A.G.A. Laboratories as part of the design certification.

**III. GENERAL INFORMATION**

VENT SIZE	VENT SECTION MATERIAL	DAMPER VANE MATERIAL	BYPASS FACTOR WHEN CLOSED	SHIPPING WEIGHT
4"	cast iron	16 ga. aluminized Steel	10%	5 lbs
5"	cast iron	16 ga. aluminized Steel	10%	6 lbs
6"	cast iron	16 ga. aluminized Steel	10%	7 lbs
7"	cast iron	16 ga. aluminized Steel	10%	8 lbs
8"	cast iron	16 ga. aluminized Steel	10%	10 lbs
9"	cast iron	16 ga. aluminized Steel	10%	11 lbs
10"	cast iron	16 ga. aluminized Steel	10%	12 lbs
12"	cast iron	16 ga. aluminized Steel	10%	17 lbs

**IV. ELECTRICAL**

- MINIMUM WIRING REQUIREMENTS ..... 18 GAUGE, 90°C
- THERMOSTAT ANTICIPATION ..... 0.1 AMP + GAS VALVE CURRENT
- DAMPER DRIVE MOTOR
  - Power draw requirement ..... 6 WATTS AT 24 VAC WHEN CLOSED OR CLOSING
  - Torque (running) ..... 26 IN./OZ. MINIMUM AT 20.4 VOLTS
  - Timing ..... TO CLOSE, 8 SECONDS; TO OPEN, 3 SECONDS (NOM.)
  - Characteristics ..... POWER CLOSE, SPRING OPEN
  - Type ..... SYNCHRONOUS
- SWITCHING ..... 2 PRECISION SNAP ACTING SWITCHES, 5 AMP RES., 3 AMP IND. AT 125 VAC, 250 VAC
- P.C. BOARD ..... 2 OZ./FT<sup>2</sup> ONE SIDE COPPER, HEAT RESISTANT, FLAME RETARDANT

THE SK22 IS DESIGNED TO BE USED WITH A CLASS 2, 24 VOLT TRANSFORMER OR A 30 VAC MAXIMUM VOLTAGE SOURCE.

## V. MECHANICAL

Damper vane .....	16 gauge aluminized steel
Drive rod-actuator .....	1/8" x 1/4" x required length, chrome plated cold rolled steel
Mounting plate .....	aluminum, 14 gauge
Actuator cover .....	plastic
Maximum allowable stack temperature .....	550° F

## VI. FEATURES

Damper opens on power failure - Adaptable to line voltage or millivoltage applications - 100,000 trouble-free operations in life cycle test - Cast iron construction of vent pipe section - Burner "OFF" before start of damper close - Normal burner operations with damper disabled open - No burner operation with damper disabled closed - Two external damper position indicators - Direct drive, no-linkage end switch for burner off/on cycle - Low voltage (24V) circuitry compatible with standing pilot and intermittent ignition devices - A.G.A. retrofit certification ANSI Z21.66 - Damper safety circuit disables damper to the open position if damper interlock switch malfunctions closed while maintaining normal burner operation - Free-wheeling lost motion clutch permits free rotation of vane during installation without gear damage - Actuator assembly is replaceable.

## VII. DIMENSIONS

Vent Size	A		B		C	
	in	mm	in	mm	in	mm
4"	4.6"	116	6.3"	161	8.5"	215
5"	5.6"	141	6.8"	174	9.5"	240
6"	6.6"	167	7.3"	186	10.5"	266
7"	7.6"	192	7.8"	199	11.5"	291
8"	8.6"	217	8.3"	212	12.5"	316
9"	9.6"	243	8.8"	225	13.5"	342
10"	10.6"	268	9.3"	237	14.5"	367
12"	12.6"	319	10.3"	263	16.5"	418

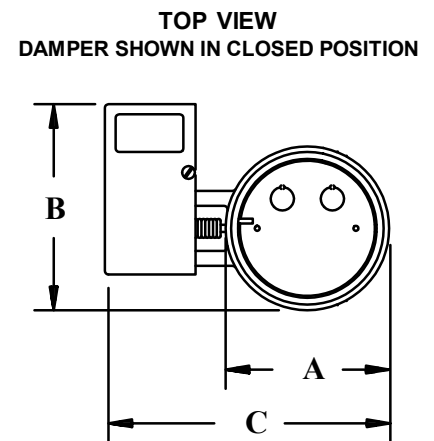
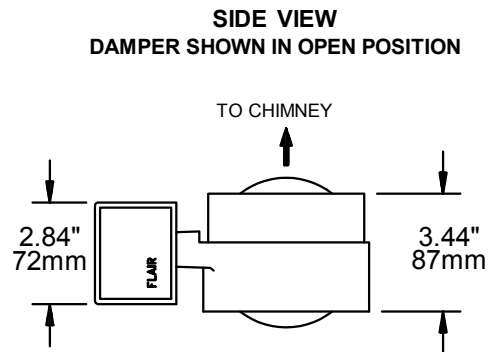

## VIII. INSTALLATION INSTRUCTIONS

### A. BEFORE YOU START TO INSTALL:

Series 19 requires gas valve redundancy.

- (1) Perform pre-installation inspection as required by ANSI specification Z21.66 (see page 7, Exhibit A.).
- (2) Turn off all electrical power, gas supply and wait for system to cool.
- (3) Select a proper, convenient location (See Fig. 1, 2). The damper device must be installed so that the damper position indicator is visible and the controller unit is accessible for wiring.
- (4) Carefully unpack the unit. The damper is spring loaded, and should move to an open position after removing vane hold-down clip.
- (5) Caution: Label all wires prior to disconnection when servicing controls. Wiring errors can cause improper and dangerous operation.

### B. PROCEED AS FOLLOWS:

- (1) Separate the vent pipe directly on top of the draft hood or diverter and insert the casting. The arrow installed between the housing and actuator should point in direction of vent gas flow (towards chimney).
- (2) Reassemble the vent piping. Be sure the casting is well seated. (See Fig. 2, Fig. 4, or Fig. 5 if support or "screw-together" assembly is required). Do not proceed if heating appliance is a gas-fired boiler with a low limit control or tankless coil. Consult factory for wiring information. Be prepared to give complete name, series, model number and description of boiler control (AQUASTAT) being used.
- (3) Insure that the damper device is interlocked with all the appliance's automatic valves. Use wiring harness, available separately for standard models, or use special connector with 18 G.A. wire with at least .028(.7mm) thick insulation.
- (4) Restore electrical power, turn on gas supply and light pilot (if applicable).

### C. AFTER INSTALLATION:

- (1) Operate system through 3 complete cycles to check for opening and closing in proper sequence, and proper hi-limit control of burner operation. (See Fig. 6 for Position Indicator.).
- (2) Perform installation checks as required by ANSI specification Z21.66 (See Page 7, Exhibit B).
- (3) Check the trouble-shooting section if problems arise with the installation.

# WIRING DIAGRAMS

CONSULT FACTORY FOR APPLICATION ON BOILER (HYDRONIC) SYSTEMS WITH TANKLESS COIL OR LOW LIMIT CONTROL.

## LOW VOLTAGE SYSTEMS

### FURNACE OR BOILER, LOW VOLTAGE WITHOUT RELAY CONTROL

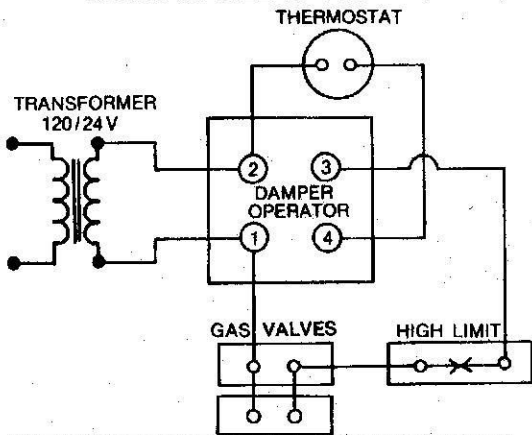

### FURNACE OR BOILER, LOW VOLTAGE WITH RELAY CONTROL

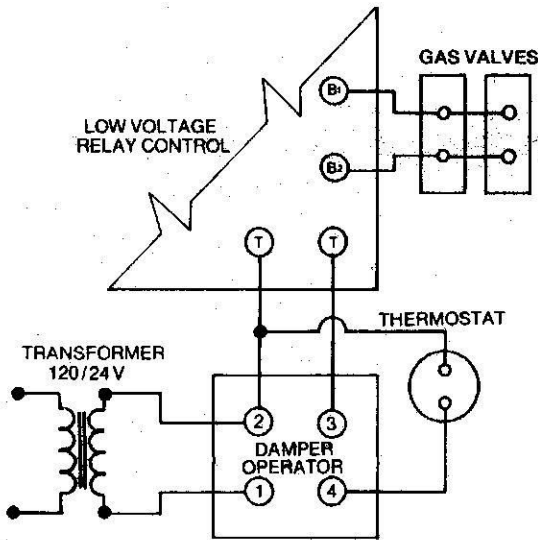

### FURNACE, LOW VOLTAGE, WITH RELAY CONTROL HEATING/COOLING

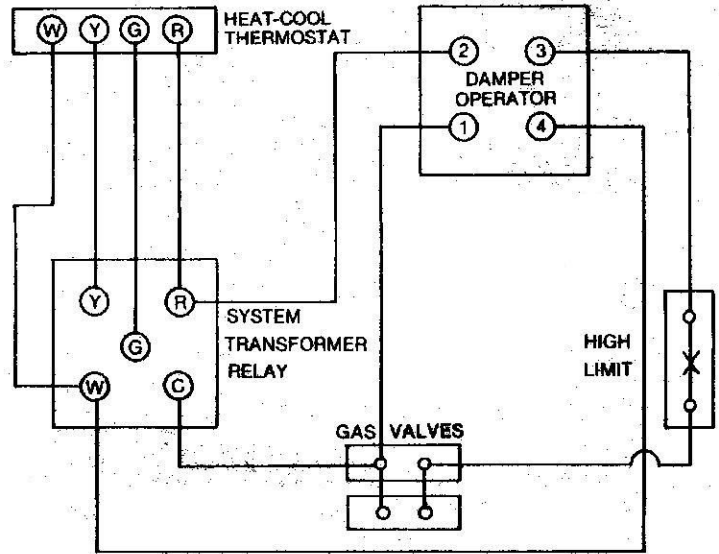

CONSULT FACTORY FOR WIRING INSTRUCTIONS WHEN STACK DAMPER IS TO BE INSTALLED IN CONJUNCTION WITH A NON-STANDING PILOT, INTERMITTENT IGNITION DEVICE (IID).

An Adequate Electrical Supply Must Be Provided.

SYSTEM SCHEMATIC

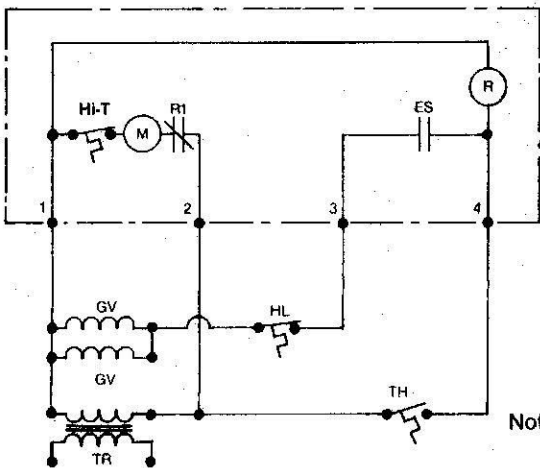

LADDER DIAGRAM

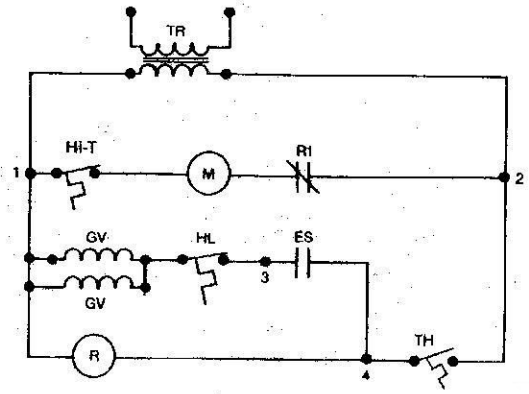

### LEGEND

- M Damper Motor
- R Relay
- ES End Switch
- TR Transformer 120/24V
- HL High Limit
- TH Thermostat, Heating, Low Voltage
- \* Hi-T Hi-Temperature Protector
- GV 24V Gas Valve

Note: Circuit shown with damper in closed position; no call for heat.

\*Series 21 Only

Use Band Iron For Support If Required  
(Replace any damaged or rusted vent pipe)

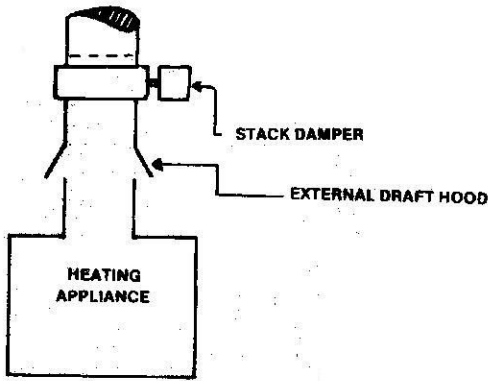

VERTICAL INSTALLATION  
Fig. 1

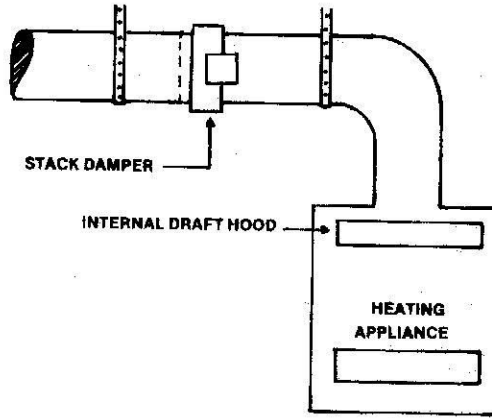

HORIZONTAL OR SLOPING INSTALLATION \*  
Fig. 2

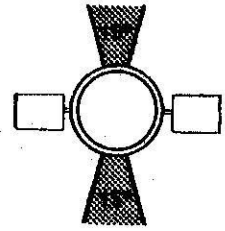

\*INSTALL OPERATOR IN ANY POSITION AS SHOWN ABOVE. DO NOT INSTALL THE OPERATOR ABOVE THE VENT PIPE (TO AVOID EXCESSIVE HEAT) OR BELOW THE VENT PIPE (TO AVOID POSSIBLE CONDENSATE DAMAGE).

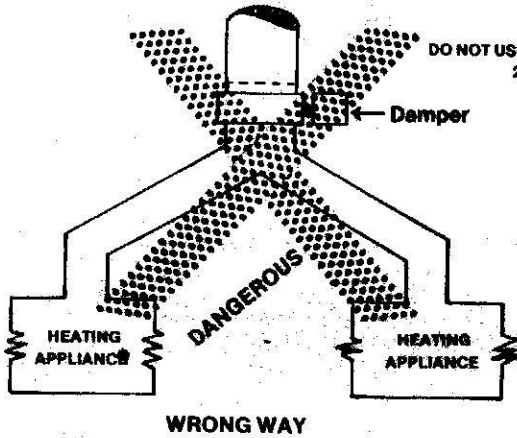

CAUTION  
DO NOT USE ONE STACK DAMPER TO CONTROL 2 HEATING APPLIANCES

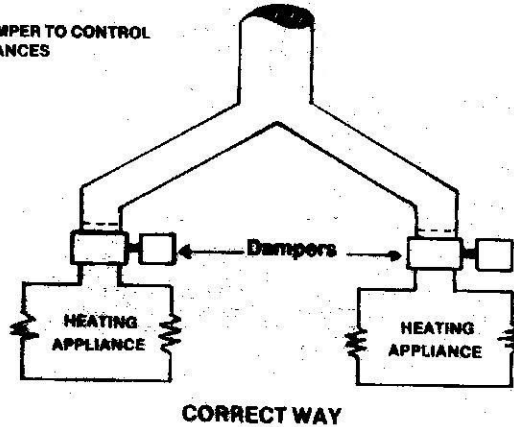
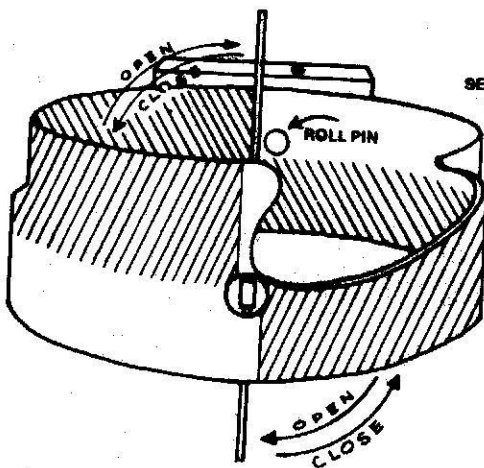

Fig. 4



SECTION REMOVED TO SHOW SHADED AREA

CAUTION

TO PREVENT INTERFERENCE WITH DAMPER VANE MOVEMENT, SCREWS OR POP RIVETS MUST NOT BE LOCATED IN SHADED AREAS OF THE CASTING, AND MUST NOT EXCEED ONE-HALF (1/2) INCH IN LENGTH.

Fig. 5

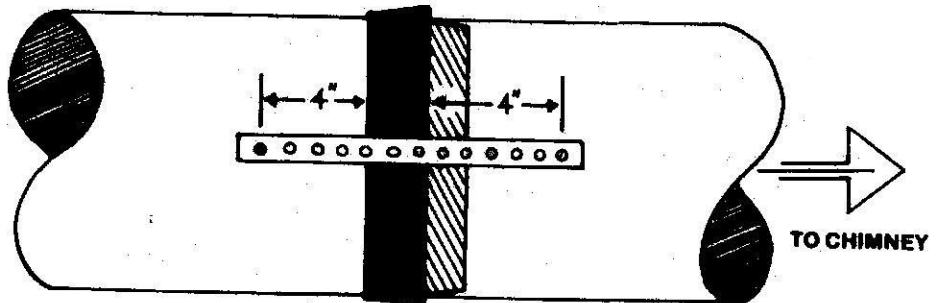

INSTALL BAND IRON AS REQUIRED. USE 1/2" SELF-TAPPING SCREWS OR POP RIVETS AND LOCATE THEM A MINIMUM OF 4" FROM THE EDGE OF THE CASTING.

Fig. 6

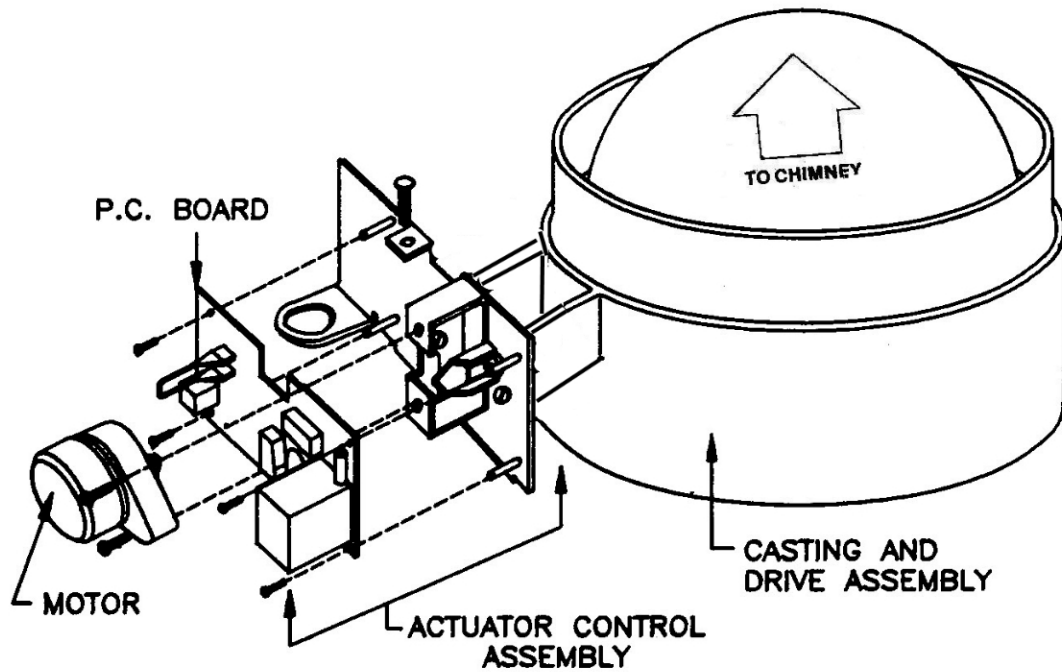

**NOTE:** Consult your local distributor for part numbers and pricing. **FOR SAFETY REASONS,** only component assemblies as shown are available. Orders for sub-assemblies will not be accepted.

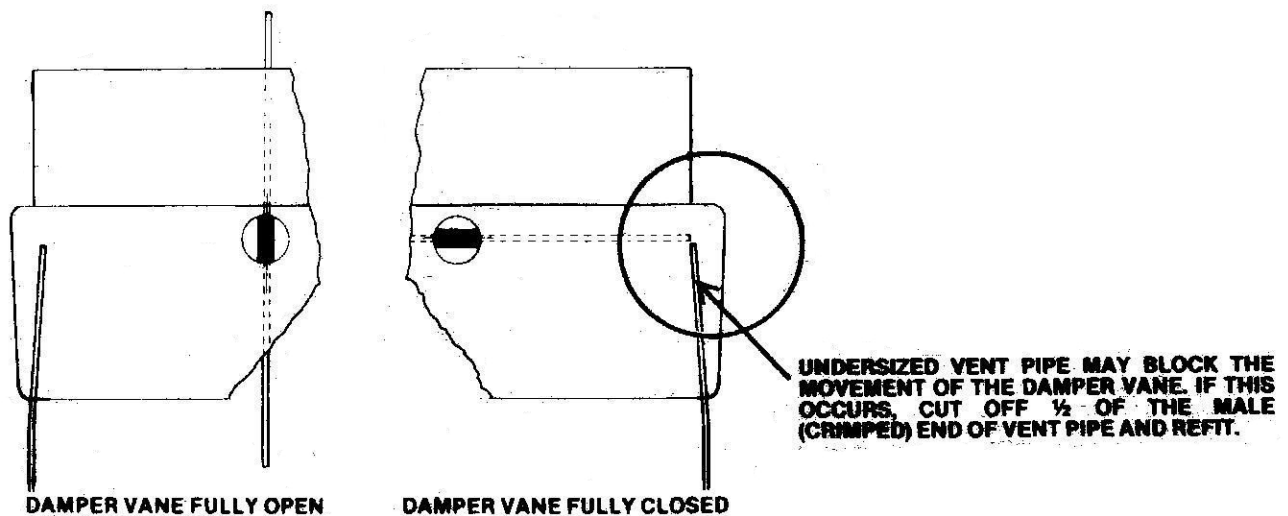

**DAMPER POSITION INDICATOR MAY BE VIEWED THROUGH HOLE IN THE CASTING ON THE SIDE OPPOSITE THE OPERATOR.**

**Fig. 8**

# IMPORTANT

- THE STEP-BY-STEP INSPECTION AND INSTALLATION PROCEDURES AS SPECIFIED IN EXHIBITS A AND B MUST BE FOLLOWED
- THE QUALIFIED INSTALLER MUST FILL IN LABEL ON THE SIDE OF THE OPERATOR
  - AN ADEQUATE ELECTRICAL SUPPLY MUST BE PROVIDED

## EXHIBIT A PROCEDURE FOR SAFETY INSPECTION OF AN EXISTING APPLIANCE INSTALLATION

The following procedure is intended as a guide to aid in determining that an appliance is properly installed and is in a safe condition for continuing use.

This procedure is predicated on central furnace, boiler and water heater installations, and it should be recognized that generalized procedures cannot anticipate all situations. Accordingly, in some cases deviation from this procedure may be necessary to determine safe operation of the equipment:

- This procedure shall be performed prior to installation of the automatic vent damper device.
- If it is determined there is a condition which could result in unsafe operation, the appliance should be shut off and the owner advised of the unsafe condition. Do not install the automatic vent damper device until the unsafe condition has been corrected.

The following steps are to be followed in making the safety inspection:

- Conduct a gas leakage test of the appliance piping and control system downstream of the shut off valve in the supply line to the appliance.
- Visually inspect the venting system for proper size, horizontal pitch and vent termination, and determine there is no blockage or restriction, leakage, corrosion and other deficiencies which could cause an unsafe condition.
- Determine that the chimney or vent is acceptable to the authority having jurisdiction.
- Shut off all gas to the appliance and shut off any other fuel-gas burning appliance within the same room. Use the shut off valve in the supply line to each appliance.
- Inspect burners and crossovers for blockage and corrosion.
- Applicable only to furnaces - inspect heat exchanger for cracks, openings or excessive corrosion.
- Applicable only to boilers - inspect for evidence of water or combustion product leaks.
- Insofar as is practical, close all building doors and windows and all doors between the space in which the appliance is located and other spaces of the building. Turn on clothes dryers. Turn on any exhaust fans, such as range hoods and bathroom exhausts, so they will operate at maximum speed. Do not operate a summer exhaust fan. Close fireplace dampers. If, after completing Steps 9 through 14, it is believed sufficient combustion air is not available, refer to local codes, or in the absence of local codes, to the National Fuel Gas Code, ANSI Z223.1- (most current edition) (NFPA 54), for guidance.
- Place in operation the appliance being inspected. Follow the lighting instructions. Adjust thermostat so appliance will operate continuously.
- Determine that the pilot(s), when provided, is burning properly and that main burner ignition is satisfactory by interrupting and reestablishing the electrical supply to the appliance in any convenient manner.

If the appliance is equipped with a continuous pilot(s), test the pilot safety device(s) to determine if it is operating properly by extinguishing the pilot(s) when the main burner (s) is off and determining, after 3 minutes, that the main burner gas does not flow upon a call for heat.

If the appliance is not provided with a pilot(s), test for proper operation of the ignition system in accordance with the appliance manufacturer's lighting and operating instructions.

- (a) Visually determine that main burner gas is burning properly, i.e., no floating, lifting or flashback. Adjust the primary air shutter(s) as required.
- (b) If the appliance is equipped with high and low flame controlling or flame modulation, check for proper main burner operation at low flame.
- Test for spillage at the draft hood relief opening after 5 minutes of main burner operation. Use the flame of a match or candle, or smoke from a cigarette, cigar or pipe.
- Turn on all other fuel-burning appliances within the same room so they will operate at their full inputs. Follow lighting instructions for each appliance.
- Repeat Steps 11 and 12 on the appliance being inspected.
- Return doors, windows, exhaust fans, fireplace dampers and any other fuel-gas burning appliances to their previous conditions of use.
- Applicable only to furnaces - Check both the limit control and the fan control for proper operation. Limit control operation can be checked by blocking the circulating air inlet or temporarily disconnecting the electrical supply to the blower motor and determining that the limit control acts to shut off the main burner gas.
- Applicable only to boilers -
  - Determine that the water pumps are in operating condition.
  - Test low water cutoffs, automatic feed controls, pressure and temperature limit controls, and relief valves in accordance with the manufacturer's recommendations to determine they are in operating condition.

For continued safe operation, the homeowner should check all flue product carrying areas of the appliance, its vent system, and the damper device at least once a year. Particular attention should be given to the replacement of parts deteriorated by corrosion or other sources. Such replacement must be done by a qualified installing agency, who shall carry out an annual inspection of the appliance-device combination.

## EXHIBIT B PROCEDURE FOR INSTALLING ELECTRICALLY OPERATED AND MECHANICALLY ACTUATED AUTOMATIC VENT DAMPER DEVICES ON EXISTING APPLIANCES

This procedure is intended as a guide to aid in safely installing an electrically operated or mechanically actuated automatic vent damper device on an existing appliance. This procedure is based on the assumption that the history of the specific appliance has been one of safe and satisfactory operation. This procedure is predicated on central furnace, boiler and water heater installations, and it should be recognized that generalized procedures cannot anticipate all situations. Accordingly, in some cases deviation from this procedure may be necessary to determine safe operation of the equipment.

The following steps are to be followed in making the modifications:

- Perform a safety inspection of the existing appliance installation. See Exhibit A for the recommended procedure for such a safety inspection.
- Shut off all gas and electricity to the appliance. To shut off gas use the shut off valve in the supply line to the appliance.
- Install the automatic vent damper device in strict accordance with the manufacturer's installation instructions. Make certain the device is not located in that portion of the venting system which serves any appliance other than the one for which the damper is installed.
- Make certain wiring connections are tight and wires are positioned and secured so they will not be able to contact high temperature locations.
- When an additional automatic valve has been incorporated or an existing gas control replaced, conduct a gas leakage test of the appliance piping and control system downstream of the shut off valve in the supply line to the appliance.
- Visually inspect the modified venting system for proper horizontal pitch.
- Check that the damper and gas valve(s) are in the correct operating sequence.
  - The damper must be in the full open position before the gas valve(s) opens.
  - The damper must remain in the full open position while the gas valve(s) is open.
  - The gas valve(s) must be closed before the damper begins its return to the closed position.
  - The damper shall remain in the closed position during the off cycle of the appliance.
- Determine the amperage draw of the gas control circuit and damper device.
  - Check appliance transformer for adequate capacity.
  - Check heat anticipator in comfort thermostat to determine it is properly adjusted.
- Sequence the appliance through at least three normal operating cycles.
- Insofar as is practical, close all building doors and windows and all doors between the space in which the appliance is located and other spaces of the building. Turn on clothes dryers. Turn on any exhaust fans, such as range hoods and bathroom exhausts, so they will operate at maximum speed. Do not operate a summer exhaust fan. Close fireplace dampers.
- Place appliance in operation. Follow the lighting instructions. Adjust thermostat so appliance will operate continuously.
- Test for spillage at the draft hood relief opening after 5 minutes of main burner operation. Use the flame of a match or candle or smoke from a cigarette, cigar or pipe.
- (a) Visually determine that main burner gas is burning properly, i.e., no floating, lifting or flash-back. Adjust the primary air shutter(s) as required.
- (b) If the appliance is equipped with high and low flame controlling or flame modulation, check for proper main burner operation at low flame.
- Determine that the pilot(s), when provided, is burning properly and that main burner ignition is satisfactory by interrupting and reestablishing the electrical supply to the appliance in any convenient manner. If the appliance is equipped with a continuous pilot(s), test the pilot safety device(s) to determine if it is operating properly by extinguishing the pilot(s) when the main burner(s) is off and determining, after 3 minutes, that the main burner gas does not flow upon a call for heat. If the appliance is not provided with a pilot(s), test for proper operation of the ignition system in accordance with the appliance manufacturer's lighting and operating instructions.
- Applicable only to furnaces - Check both the limit control and the fan control for proper operation. Limit control operation can be checked by blocking the circulating air inlet or temporarily disconnecting the electrical supply to the blower motor and determining that the limit control acts to shut off the main burner gas.
- Applicable only to boilers -
  - Determine that the water pumps are in operating condition.
  - Test low water cutoffs, automatic feed controls, pressure and temperature limit controls, and relief valves in accordance with the manufacturer's recommendations to determine they are in operating condition.
- Label the damper device (see 1.7.5) with information as to:
  - Name of qualified agency responsible for damper installation.
  - Date of installation.

## TROUBLE-SHOOTING GUIDE (listed in order of probability)

SYMPTOM	POSSIBLE CAUSE	REMEDY
Damper cycles after call for heat is satisfied.	Normal until temp. stays below 225°F.	If cycling is excessive, replace temperature limit.
Heating required and burner will not operate. Damper closed.	Thermostat is set wrong.	Resest room thermostat to call for heat.
Heating required and burner will not operate. Damper open.	No electrical power to damper.	Turn on switch, replace fuse, reset circuit breaker or repair wiring.
	Improper wiring.	Recheck and correct any wiring errors.
	Defective burner components.	Check, repair or replace burner components (thermocouples, gas valve, pilot, IID, etc.).
	Damaged or defective damper motor.	Replace damper motor & board assy.
Burner operates normally, damper will not close.	Temperature in vent exceeds 225°F.	Allow system to cool. If damper still does not close, replace temperature limit.
	Damper is blocked open.	Check for free damper movement and remove blockage.
	Improper wiring.	Recheck and correct any wiring errors.
	Damaged or defective damper motor.	Replace damper motor.
	Damaged or defective temperature limit.	Replace temperature limit.
Burner will not operate. Damper closed and will not open.	No call for heat.	Reset thermostat (heat or hot water) to call for heating.
	Damper is blocked closed.	Check for free damper movement and remove blockage.
	Improper wiring.	Recheck and correct any wiring errors in line and low voltage circuits.
Burner will not operate. Damper operates normally.	Improper wiring.	Recheck and correct any wiring errors.
	Defective burner components.	Check, repair or replace burner components.
Burner operates before damper opens.	Improper wiring.	Recheck and correct any wiring errors.
Damper vane stops in other than fully open or fully closed position.	Damper is blocked.	Check for maximum 95° damper movement. If less than 90°, remove blockage. Check and correct badly fitting vent piping.
	Missing or broken drive screw.	Replace stainless steel drive screw.
Intermittent burner operation. Damper operates normally.	Loose or broken wires.	Recheck and correct any wiring errors.
	Damaged or defective switch.	Replace damper motor.
Burner operates with damper closed.	Improper wiring.	Recheck and correct any wiring errors.
	Boiler equipped with tankless coil or low limit and not wired properly.	Consult factory for required wiring modifications.

**INSTALLATION AND SERVICE SHOULD BE PERFORMED BY A QUALIFIED INSTALLING OR SERVICE AGENCY.**

© FLAIR INTERNATIONAL 1993

- FLAIR AND STACK PACK ARE REGISTERED TRADEMARKS OF FLAIR INTERNATIONAL
- SK AND SK22 ARE TRADEMARKS OF FLAIR INTERNATIONAL CORPORATION